



Audio Engineering Society Convention Paper 5336

Presented at the 110th Convention
2001 May 12–15 Amsterdam, The Netherlands

This convention paper has been reproduced from the author's advance manuscript, without editing, corrections, or consideration by the Review Board. The AES takes no responsibility for the contents. Additional papers may be obtained by sending request and remittance to Audio Engineering Society, 60 East 42nd Street, New York, New York 10165-2520, USA; also see www.aes.org. All rights reserved. Reproduction of this paper, or any portion thereof, is not permitted without direct permission from the Journal of the Audio Engineering Society.

The Quick Reference Guide to Multichannel Microphone Arrays Part 1 : using Cardioid Microphones

Michael Williams (1) and Guillaume Le Dû (2)

(1) "Sounds of Scotland", Le Perreux sur Marne, 94170, France

(2) Radio France, Paris, 75016, France

ABSTRACT

No one microphone array is able to fulfil the needs of the sound engineer in all the different sound recording environments he encounters. This paper presents over 220 Multichannel Microphone Arrays using cardioid microphones, and describes their particular characteristics with respect to front-triplet, lateral-pair and back-pair coverage together with the specific segment offset values when required for Critical Linking. Arrays have been chosen so as to assist the sound engineer in his search for the optimum microphone array for a given recording situation

INTRODUCTION

The race is on for the pot of gold at the end of the rainbow! Who will be the first to find the magic multichannel microphone array that will be the optimum solution for all our needs in this new field of sound recording? Quite a few proposals have been made already but the pot of gold is still no nearer! However, as with the search for the ideal stereo pair, each solution has specific advantages and inconveniences, but none can be considered universal. But of course it is the quest for the ideal universal solution that is illusory – we must design each system according to the needs of each individual recording context.

It is certain that we frequently encounter rather similar circumstances as with, for instance, a Symphony Orchestra in a purpose made Concert Hall. But there are so many variants related to the size of the sound source, the early reflection sound

field and the overall reverberation, that the sound engineer must have a wide selection of arrays at his disposal to do justice to the multitude of other situations that he must inevitably encounter.

The process of Multichannel Microphone Array Design is highly complex, due to the interaction of the many parameters that are involved. It would seem almost impossible to envisage undertaking the complete multichannel design process just before the beginning of a recording session. Unfortunately this is the moment when the sound recording engineer is more or less in possession of the complete range of characteristics of the sound field to be recorded. This paper will present a quick reference guide to over 220 different Multichannel Microphone Array configurations to assist the sound engineer in quickly choosing a system adapted to each particular circumstance.

All systems described present good Critical Linking; i.e. the reproduction of the sound field is continuous without any « holes » or « overlaps ». However as a complete description of each system would require as many pages as there are systems, it was considered more reasonable to present the characteristics of each of the arrays grouped within a table covering each specific value of Front Triplet Coverage. Within each of these Front Triplet Coverage values a range of possible combinations are suggested. In general Microphone Position Offset is used to obtain Critical Linking of the Front Triplet Segments whereas Electronic Time Offset is normally required to obtain Critical Linking of the Lateral Segments. Microphone Position Offset, as its' name implies, is obtained purely by the correct position and orientation of the microphones in the array, however, Electrical Time Offset needs specific time delays to be introduced into certain channels. The sound recording engineer does not always have the possibility to adjust Electrical Time Offset with the equipment available for a recording session. For this reason a few selected arrays have been described which have Natural Critical Linking, i.e. the parameters of the array have been chosen so that no electrical offset is necessary to obtain Critical Linking. The orientation of each microphone and their corresponding « X » and « Y » coordinates are the only parameters that have to be set up to obtain Critical linking with these specific arrays.

The concept of Critical Linking means that the impression of a continuous sound field is reproduced no matter what the orientation of the listener within the loudspeaker set-up. This allows a certain freedom of rotational movement of the head, but does not obviously change the need for the listener to be in the centre of the loudspeaker system, commonly called « the sweet spot ». But « Oh! How sweet » is this experience with a good recording made with a correctly designed Multichannel Microphone Array!

Previous AES papers (1)(2) have described the concept of Segment Coverage and Critical Linking, together with the different types of Offset that are necessary to obtain Critical Linking. If the reader is not familiar with these terms he should refer to these previous publications.

MMA DESIGN PROCEDURE

General Overall Strategy

As with the choice of a dual microphone array for stereophonic sound recording, the first stage of array design is to determine the probable position of the microphone system, and therefore to measure the angle of the sound source as « seen » by the microphone array. Details for the construction of a suitable measuring instrument are given in Ref (3). With a stereophonic microphone array the Stereophonic Recording Angle (SRA) is chosen according to the amount of « side room » to be left on either side of the sound source. In general a small musical sound source such as a quatuor needs an SRA that is about 10% wider than the actual sound source (the extra 10% on each side is called the « side room »). However for a wider sound source, such as a Symphony Orchestra, the SRA is usually about 10% smaller than the total sound stage. This enables better resolution in the centre part of the orchestra, but obviously to the detriment of the extremities of the orchestra, which will become somewhat crushed onto the left and right loudspeakers in reproduction.

With the Multichannel Microphone Array we have the added advantage of a wider reproduction stage. We are therefore not limited to the 60° of stereophonic reproduction. Although the complete use of the side segments for direct sound is not advisable due to the progressively worsening localisation characteristics on the side, it is nevertheless possible to exploit the sound reproduction further than the « 30° + 30° » defined by the front three loudspeakers. A 10° or 20° spread of the sound source into the lateral segments is possible, with the added advantage of a better feeling of envelopment of the listener and, of course, considerably better reproduction of early reflection groups. However it remains to be seen as to precisely how much more spread is possible with a wide sound source and also whether we

still need to stay within the front 60° with the smaller sources. In practice this obviously means that we need to use a Multichannel Microphone Array that allows us to fully exploit the recording and reproduction characteristics of the lateral segments.

In the design of a dual microphone pair for stereophonic sound recording complete freedom exists to choose any combination of distance and angle, for the desired Coverage. This allows the sound engineer to choose any system from coincident directional microphones through hybrid combinations of distance and angle to the purely time dependent spaced pair of omnidirectional microphones. In the multichannel array design a purely intensity dependent system is not feasible if we are looking for a Critically Linked surround sound system. However careful examination of the multichannel microphone array configurations presented in the tables will demonstrate that it is possible to select systems that have either Time or Intensity Dominance according to the options chosen in design. It remains to be seen whether a time dominant, or Intensity Dominant system, is preferable for better localisation in the lateral segments.

The completely « surround sound » characteristics of natural reverberation mean that a continuous sound field pick-up around the array becomes a necessity. Attention to Critical Linking therefore becomes of paramount importance and is therefore integrated into the total process of Multichannel Microphone Array Design presented in this paper.

The majority of musical sound recording situations that we encounter concern the reproduction of a limited sound stage as seen in the concert hall or theatre. The research for a satisfactory reproduction of the completely surrounding direct sound source, although technically very challenging, is not part of our daily bread.

In general the Multichannel Microphone Array has a considerable wing span somewhat like the proverbial « Albatross ». However careful analysis of the many arrays presented in this paper will show that this is not always the case. There are also some circumstances, for instance when a minimum of physical size is important, in which case it is necessary to neglect the reproduction characteristics of the lateral segments. But we are perforce limited to the 60° of the front sound stage (as with the standard stereophonic sound stage) created by the front three loudspeakers, and the far from satisfactory 140° of the back segment reproduction. However in this paper we are only concerned with good continuous reproduction of the total surround sound environment.

This still leaves us with the first major decision as to what coverage angle to adopt relative to the direct sound from the sound source. There are no rules as to how to go about setting up a microphone array for multichannel sound recording system. Each sound recording engineer will have his own ideas and preferences and this is of course part of the art of sound recording. However here are some guidelines as to a possible procedure :

- a) Determine the probable position of the microphone system
- b) Decide on the required reproduction angle of the direct sound source. This will determine the Coverage Angle of the Front Triplet Array. Remember that the Front Triplet Coverage will only be reproduced between the front three loudspeakers. Further "spread" will concern the side segments. If the Front Triplet Coverage angle is « smaller » than the sound source, then in reproduction there will be spread into the side segments. If the Front Triplet Coverage is wider than the sound source, then the reproduced sound source will be within the front sound stage created by the front three loudspeakers.
- c) Decide on the relative balance between Back Segment and Lateral Segment Coverage. This will determine the Back Pair Coverage characteristics.
- d) Choose your own preference concerning Intensity/Hybrid/Time Dominance. It is obviously physically impossible to have Intensity or Time Dominance

for both the Back Segment and the Lateral Segments; they will usually be complimentary. Both can of course be Hybrid combination (equal dominance between Time and Intensity).

- e) Introduce, if needed, the correct Electronic Offset values between the front Triplet and the Back Pair.
- f) Listen to the result! and start again until satisfied that you have achieved the optimum result in the circumstances.

Critical Linking with Electronic Offset versus Natural Critical Linking

The various techniques needed to obtain Critical Linking have been described in previous papers (1)(2) under chapters concerning Microphones Position Time Offset (MPTO), Electronic Time Offset (ETO) and Electronic Intensity Offset (EIO). Of these different types of offset, MPTO is of course the easiest to generate, as it is obtained simply by the physical position and orientation of the microphone. ETO however requires the fine adjustment of Time Delay between the Front Triplet and the Back Pair, a facility that is not always available on the standard mixing desk or even in post production with an Audio Workstation. On the other hand EIO is just a matter of introducing the correct constant Intensity Difference, into the microphone array within the Front Triplet or between the Front Triplet and Back Pair (EIO can be used to generate Critical Linking either in the design of the Front Triplet Coverage or in the Lateral Segment Coverage). However it must be said that the range of Critical Linking that can be obtained with EIO processing is very much more limited than with ETO. Also the difference in level between each component of the array may produce an undesirable imbalance between different parts of the Array Coverage. Detailed consideration of the design of this type of array using EIO is outside the scope of this paper.

Although «Natural Critical Linking» considerably limits the choice in array design, it has a considerable advantage in that no electronic manipulation of Segment Coverage is required. **Critical Linking is obtained purely by microphone position and orientation, not only for the Front Triplet, but also between the Front Triplet, the Lateral Segment and the Back Pair Coverage.** This type of array is operational without any further signal processing. Microphone signals can therefore be recorded direct to any 5 channel recording system without the intervention of a more complex sound mixing or signal processing stage. This is obviously an important factor when doing «on-location» recording with limited studio facilities.

Tables 1, 2 & 3 show three sets of operational Multichannel Microphone Arrays where no electrical offset is needed. The combination of «Table 1a line 3» together with «Table 1b line 3» was already presented at a paper given at the 91st AES Convention in New York (4).

Table Presentation

Seven table groups are presented covering over 220 possible microphone array configurations. The Front Triplet design is shown in each **Table «a»**, whilst **Table «b»** describes the corresponding Back Pair and Lateral Segment Coverage parameters. It is a remarkable feature of the design process that within the same table number, a specific combination chosen from **Table «b»** will automatically be Critically Linked with any combination chosen from **Table «a»** on condition that the correct ETO has been applied. The Linking function depends on the Coverage Angle and not on the angle between the microphones. Variations of distance and angle used to obtain the same Coverage Angle will automatically Critically Link to neighbouring segments. Each «Table-set : a & b» will therefore cover between 30 and 36 possible microphone arrays (except for table 3 where Critical Linking is very limited and only one Back Pair configuration is shown). Two examples of microphone layout are given in the figures immediately after each table-set.

MMAD – First Stage - Front Triplet Design

The first stage in design (as explained above) is the choice of microphone array position, and thereafter the Front Triplet Coverage. A wide range of Front Triplet Coverage values are

presented in Tables 4 to 8, allowing the sound engineer to adjust the Front Triplet Coverage from a maximum of « $90^\circ + 90^\circ$ » to a minimum of « $50^\circ + 50^\circ$ ». Critical Linking is almost impossible for smaller values of Front Triplet Coverage.

MMAD – Second Stage – Back Pair

The second stage in design is to determine the desired Back Segment Coverage. Again a wide choice of Coverage has been presented, from 90° to 40° , allowing the sound engineer to optimise the reproduction of the back segment that usually covers the reverberant field. In most cases it is better not to overload back segment coverage as this can be somewhat disconcerting when reproduced in the segment behind the listener. This means that in practice it is better to choose the lower values of Back Segment Coverage that will be spread out over the 140° of back segment reproduction and of course includes considerable Angular Distortion (5).

MMAD – Third Stage – Lateral Segments

The third stage concerning the Lateral Segment Coverage is usually considered to be the Coverage of the remaining surround sound-field angle, and will be conditioned by the distance between the Front Triplet and the Back Pair. Critical Linking will be obtained by the introduction of the correct amount of Electronic Time Offset, unless of course a combination producing Natural Critical Linking has been selected.

Other Possible Configurations

For the sake of simplicity and quick reference, only certain specific configurations have been presented in the tables, but of course there are a multitude of other configurations possible within the continuum of possible microphone distance and angle. However from the operational point of view, the large range of choice, presented in tables 1 to 8, should be enough to satisfy most sound recording situations.

Microphone Directivity

As with the design of a dual microphone stereophonic array, we are not restricted to the use of cardioid microphones. It is the intention of the authors of this paper to present, in future papers, not only a choice of microphone arrays using other first order directivity patterns, but also to suggest a wide range of possible hybrid arrays using different directivity patterns for each part of the array structure.

TABLE 1a				
FRONT TRIPLET COVERAGE 72° + 72°				
Microphone Orientation	Distance between microphones	X coordinates	Y1 coordinates (for both left and right microphones)	Microphone Position Time Offset (MPTO)
90° (R)	<i>35 cms</i>	+ 30.5 cms	17 cms	-15.6°
270° (L)		- 30.5 cms		
80° (R)	<i>37 cms</i>	+ 31 cms	20.5 cms	-6°
280° (L)		- 31 cms		
72° (R)	<i>39 cms</i>	+ 31.5 cms	23 cms	<i>No Offset</i>
288° (L)		- 31.5 cms		
60° (R)	<i>42.5 cms</i>	+ 33 cms	26.5 cms	+9°
300° (L)		- 33 cms		
50° (R)	<i>45 cms</i>	+ 34 cms	29.5 cms	+15.5°
310° (L)		- 34 cms		
40° (R)	<i>48.5 cms</i>	+ 36.5 cms	31.5 cms	+20.9°
320° (L)		- 36.5 cms		

From the above table (Front Triplet Coverage of 72° + 72°) note « the microphone orientation », « X » coordinates and « Y1 » coordinates for the desired configuration of the Front Triplet. Then choose any combination « distance / angle » from the table below and note the **distance** between the left and right Back Pair

of microphones and their **orientation**, and the « Y2 » coordinate of the back pair (with respect to the front facing centre microphone). This is all the information that you need to set up this « no offset » array which covers the complete surround sound field in five equal segments of 72° each.

TABLE 1b						
LATERAL PAIRS		BACK PAIR				
<i>Lateral Segment Coverage</i>	Electronic Time Offset ETO	<i>Back Segment Coverage</i>	Mic Orient.	Angle between mics	Distance between mics	Y2 Coord
<i>72°</i>	No Offset	<i>72°</i>	160°(R) 200°(L)	40°	48 cms	58.5 cms
<i>72°</i>	No Offset	<i>72°</i>	155°(R) 205°(L)	50°	45 cms	59 cms
<i>72°</i>	No Offset	<i>72°</i>	144°(R) 216°(L)	72°	39 cms	60 cms
<i>72°</i>	No Offset	<i>72°</i>	135°(R) 225°(L)	90°	34.5 cms	62 cms
<i>72°</i>	No Offset	<i>72°</i>	130°(R) 230°(L)	100°	32 cms	63.5 cms

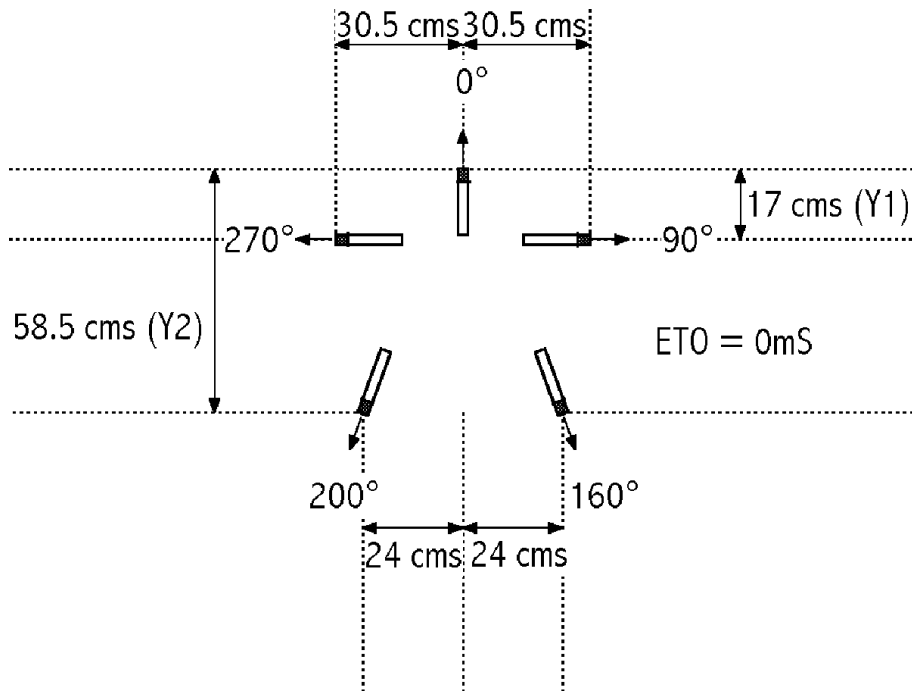

Figure 1 : Front Triplet - Table 1a / line 1 : Back Pair - Table 1b / line 1 :

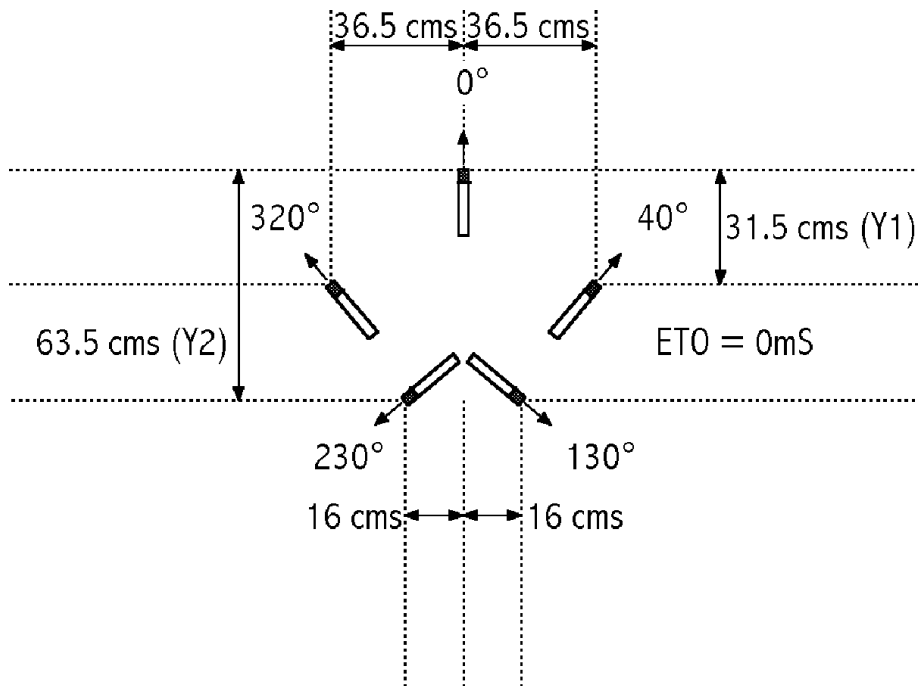

Figure 2 : Front Triplet - Table 1a / line 6 : Back Pair - Table 1b / line 6

TABLE 2a				
TABLE 2 FRONT TRIPLET COVERAGE 60° + 60°				
Microphone Orientation	Distance between microphones	X coordinates	Y1 coordinates (for both left and right microphones)	Microphone Position Time Offset (MPTO)
90° (R)	<i>46 cms</i>	+ 42.5 cms	17 cms	-23°
270° (L)		- 42.5 cms		
80° (R)	<i>48 cms</i>	+ 43.5 cms	20.5 cms	-15°
280° (L)		- 43.5 cms		
70° (R)	<i>50.2 cms</i>	+ 44.5 cms	23.5 cms	- 7°
288° (L)		- 44.5 cms		
60° (R)	<i>53 cms</i>	+ 46 cms	26.5 cms	<i>No Offset</i>
300° (L)		- 46 cms		
50° (R)	<i>56 cms</i>	+ 47.5 cms	29.5 cms	+7°
310° (L)		- 47.5 cms		
40° (R)	<i>59 cms</i>	+ 50 cms	31.5 cms	+12°
320° (L)		- 50 cms		

From the above table (Front Triplet Coverage of 60° + 60°) note « the microphone orientation », « X » coordinates and « Y1 » coordinates for the desired configuration of the Front Triplet. Then choose the combination « distance / angle » from the table below and note the **distance** between the left and right Back Pair microphone and their **orientation**, and the « Y2 » coordinate of

the back pair (with respect to the front facing centre microphone). This is all the information that you need to set up this « no offset » array which covers the complete surround sound field in five segments (the Left and Right Front Segments of 60° each, two side segments of 97.5° and a back segment of 45°.

TABLE 2b						
LATERAL PAIRS		BACK PAIR				
<i>Lateral Segment Coverage</i>	Electronic Time Offset ETO	<i>Back Segment Coverage</i>	Mic Orient.	Angle between mics	Distance between mics	Y2 Coord
97.5°	No Offset	45°	148°(R) 212°(L)	64°	73 cms	46.5 cms
97.5°	No Offset	45°	138°(R) 222°(L)	84°	67.5 cms	48 cms
97.5°	No Offset	45°	128°(R) 232°(L)	104°	62 cms	49.5 cms
97.5°	No Offset	45°	118°(R) 242°(L)	124°	58 cms	51 cms
98°	No Offset	44°	130°(R) 230°(L)	144°	54 cms	53 cms

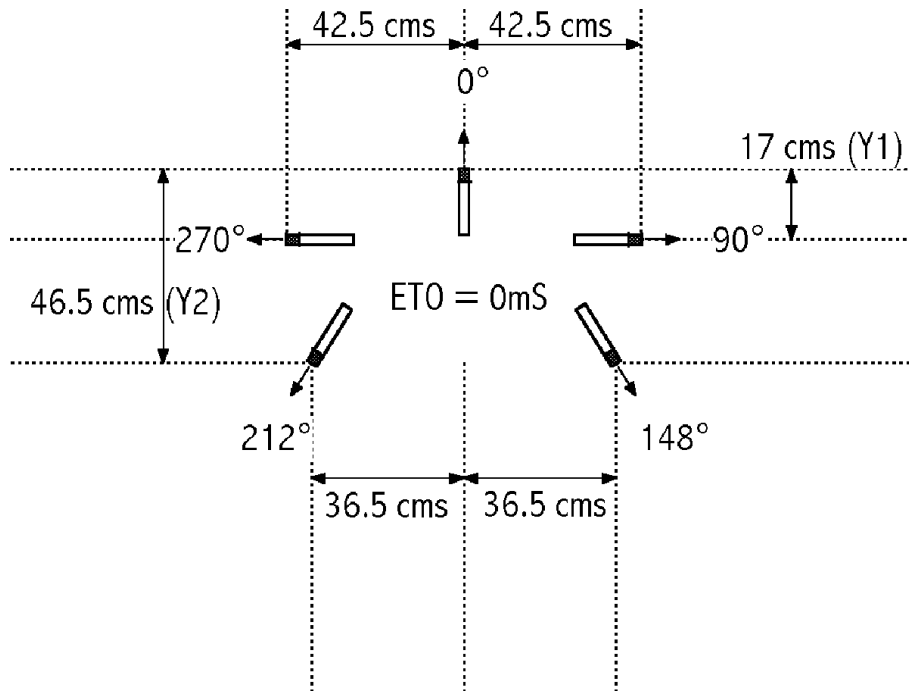

Figure 3 : Front Triplet - Table 2a / line 1 : Back Pair - Table 2b / line 1

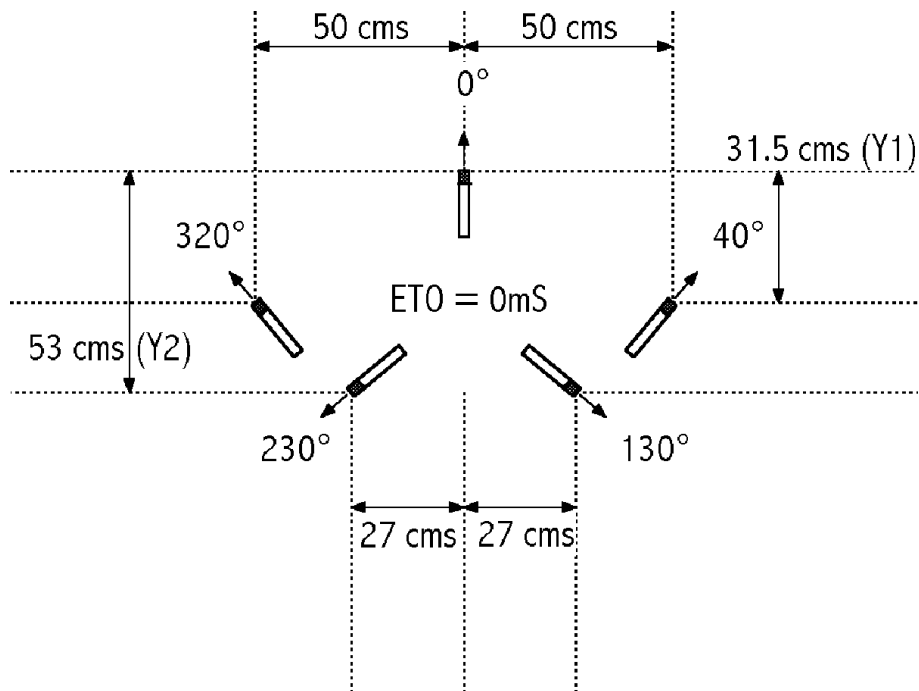

Figure 4 : Front Triplet - Table 2a / line 6 : Back Pair - Table 2b / line 5

TABLE 3a				
FRONT TRIPLET COVERAGE 50° + 50°				
Microphone Orientation	Distance between microphones	X coordinates	Y1 coordinates (for both left and right microphones)	Microphone Position Time Offset (MPTO)
90° (R)	<i>61 cms</i>	+ 58.5 cms	17 cms	-28.5°
270° (L)		- 58.5 cms		
80° (R)	<i>62 cms</i>	+ 58 cms	21 cms	-20°
280° (L)		- 58 cms		
70° (R)	<i>63.9 cms</i>	+ 59 cms	24 cms	- 13
288° (L)		- 59 cms		
60° (R)	<i>66.5 cms</i>	+ 61 cms	27 cms	-6°
300° (L)		- 61 cms		
50° (R)	<i>69.5 cms</i>	+ 63 cms	29.5 cms	No Offset
310° (L)		- 63 cms		
40° (R)	<i>72.5 cms</i>	+ 65 cms	32 cms	+6°
320° (L)		- 65 cms		

From the above table (Front Triplet Coverage of 50° + 50°) note « the microphone orientation », « X » coordinates and « Y1 » coordinates for the desired configuration of the Front Triplet. Then choose the combination « distance / angle » from the table below and note the **distance** between the left and right Back Pair microphones, and their **orientation**, and the « Y2 » coordinate

of the the Back Pair (with respect to the front facing centre microphone). This is all the information that you need to set up this « no offset » array which covers the complete surround sound field in five segments (the Left and Right Front Segments of 50° each, two side segments of 114° and a back segment of 32°

TABLE 3b						
LATERAL PAIRS		BACK PAIR				
<i>Lateral Segment Coverage</i>	<i>Electronic Time Offset ETO</i>	<i>Back Segment Coverage</i>	Mic Orient.	<i>Angle between mics</i>	Distance between mics	Y2 Coord
<i>114°</i>	No Offset	<i>32°</i>	140°(R) 220°(L)	<i>80°</i>	103 cms	44 cms

No other solutions exist for other values of Back Segment Coverage, these being the only values where intersection

between the physical parameters of the microphone array and the psychoacoustical limits are possible.

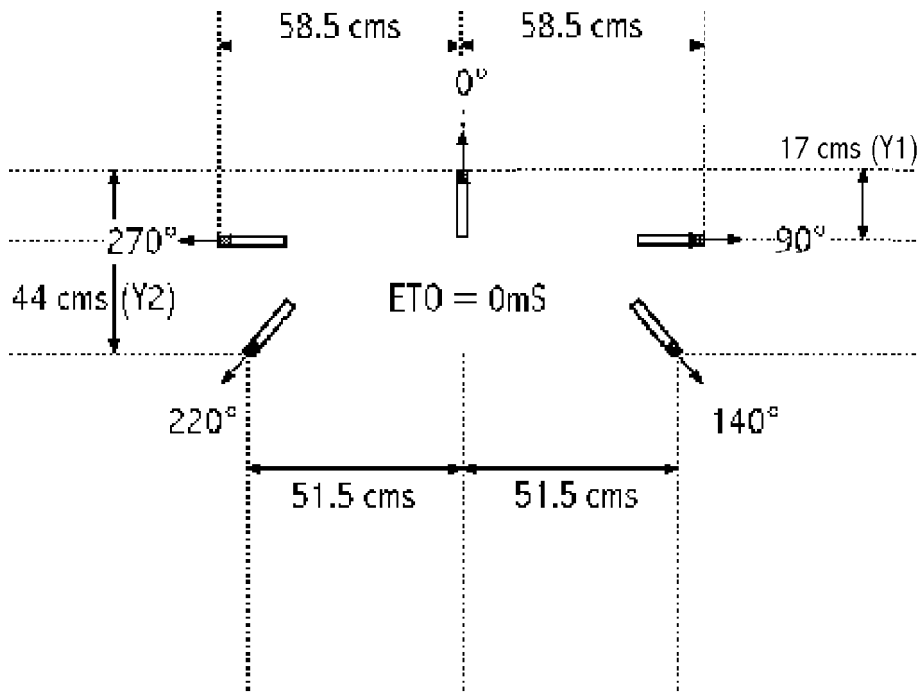

Figure 5 : Front Triplet - Table 3a / line 1 : Back Pair - Table 3b / line 1

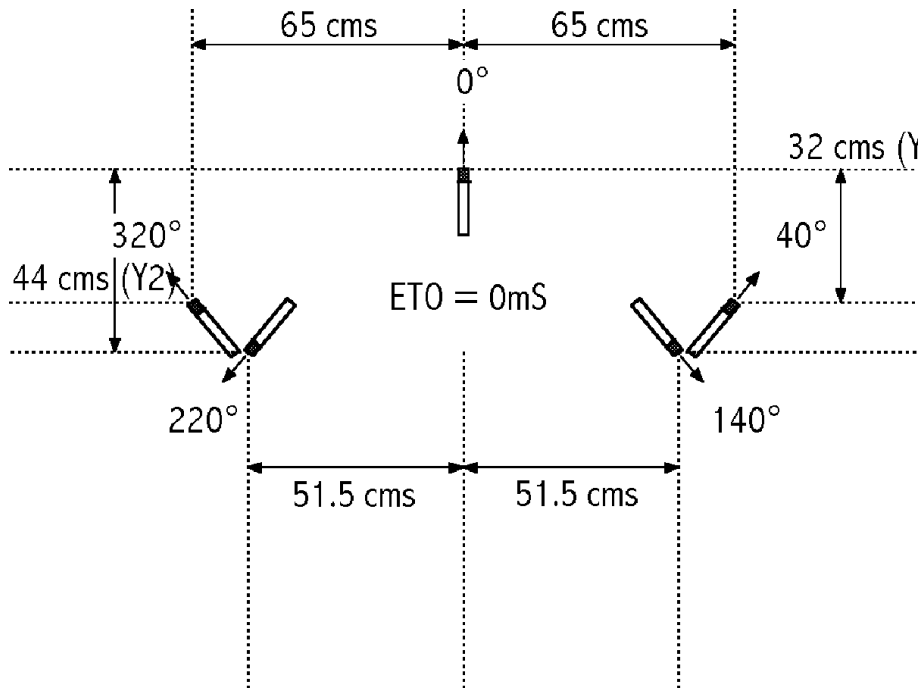

Figure 6 : Front Triplet - Table 3a / line 6 : Back Pair - Table 3b / line 1

TABLE 4a				
FRONT TRIPLET COVERAGE 90° + 90°				
Microphone Orientation	Distance between microphones	X coordinates	Y1 coordinates (for both left and right microphones)	Microphone Position Time Offset (MPTO)
90° (R)	<i>24.5 cms</i>	+ 17.3 cms	17.3 cms	<i>No Offset</i>
270° (L)		- 17.3 cms		
80° (R)	<i>27 cms</i>	+ 17.5 cms	20.5 cms	<i>+9.2°</i>
280° (L)		- 17.5 cms		
70° (R)	<i>29.5 cms</i>	+ 18 cms	23.5 cms	<i>+18°</i>
290° (L)		- 18 cms		
60° (R)	<i>32.5 cms</i>	+ 19 cms	26.5 cms	<i>+24.5°</i>
300° (L)		- 19 cms		
50° (R)	<i>35.5 cms</i>	+ 20 cms	29 cms	<i>+30.5°</i>
310° (L)		- 20 cms		
40° (R)	<i>38.5 cms</i>	+ 22 cms	31.5 cms	<i>+35.5°</i>
320° (L)		- 22 cms		

From the above table (Front Triplet Coverage of 90° + 90°) note « the microphone orientation », « X » coordinates and « Y1 » coordinates for the desired configuration of the Front Triplet. Then choose the combination « distance / angle » from the table below and note the **distance** between the left and right Back Pair microphones, and their **orientation**, and the « Y2 » coordinate

of the the Back Pair (with respect to the front facing centre microphone) and corresponding ETO (Electronic Time Offset). Please note that a negative ETO means that the Back Pair will be delayed with respect to the Front Triplet by the requisite amount. This is all the information that you need to set up the array.

TABLE 4b						
LATERAL PAIRS		BACK PAIR				
<i>Lateral Segment Coverage</i>	Electronic Time Offset ETO	<i>Back Segment Coverage</i>	Mic Orient.	Angle between mics	Distance between mics	Y2 Coord
<i>45°</i>	- 0.98 mS	<i>90°</i>	140°(R) 220°(L)	<i>80°</i>	27 cms	103 cms
<i>50°</i>	- 0.9 mS	<i>80°</i>	140°(R) 220°(L)	<i>80°</i>	32 cms	94 cms
<i>55°</i>	- 0.94 mS	<i>70°</i>	135°(R) 225°(L)	<i>90°</i>	36 cms	90 cms
<i>60°</i>	- 1.05 mS	<i>60°</i>	135°(R) 225°(L)	<i>90°</i>	45 cms	86.5 cms
<i>65°</i>	- 1.23 mS	<i>50°</i>	130°(R) 230°(L)	<i>100°</i>	55 cms	87.5 cms
<i>70°</i>	- 1.5 mS	<i>40°</i>	120°(R) 240°(L)	<i>120°</i>	68 cms	98 cms

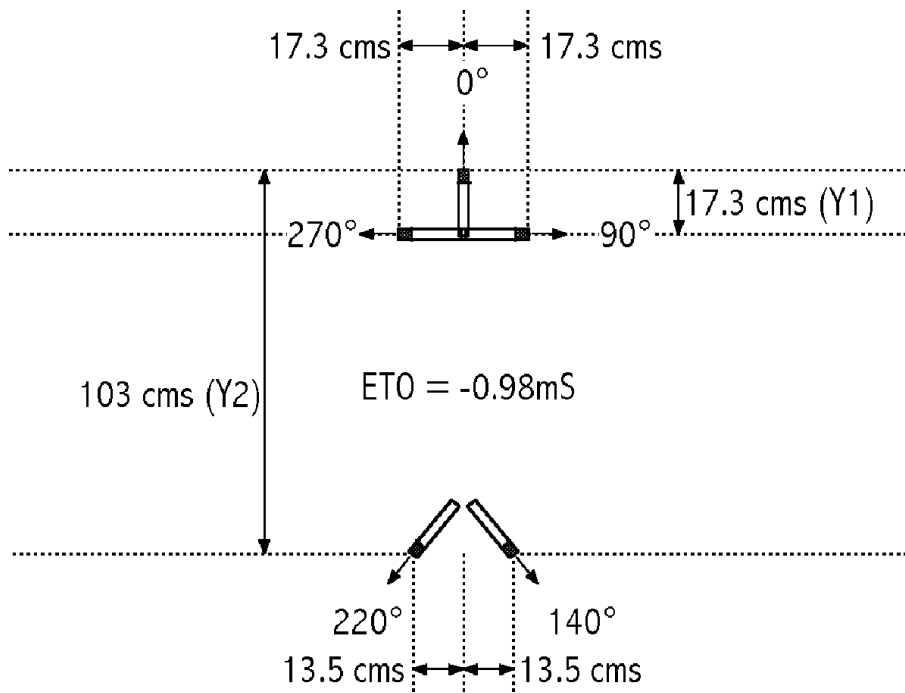

Figure 7 : Front Triplet - Table 4a / line 1 : Back Pair - Table 4b / line 1

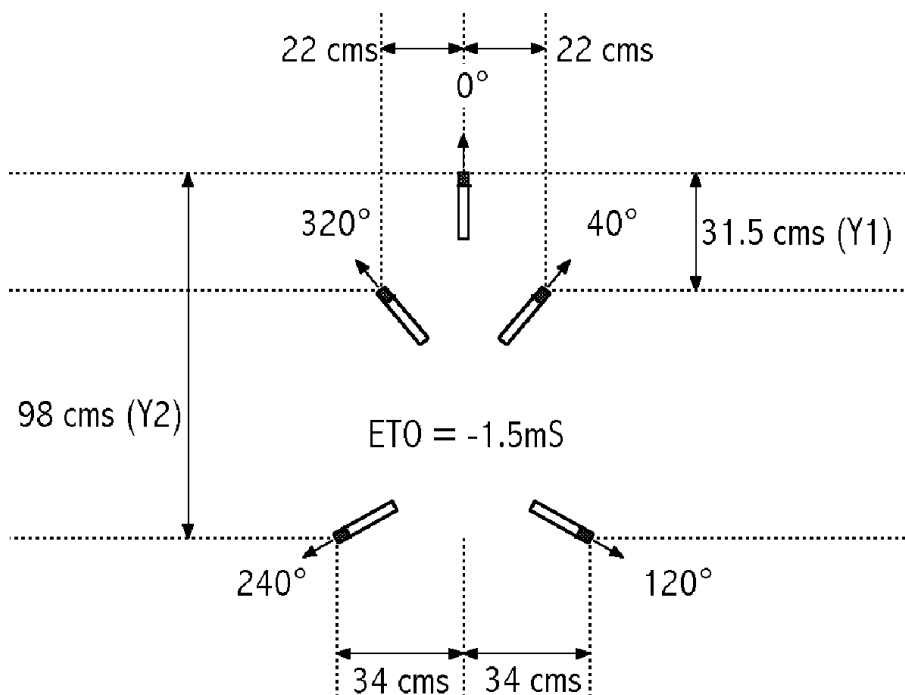

Figure 8 : Front Triplet - Table 4a / line 6 : Back Pair - Table 4b / line 6

TABLE 5a				
FRONT TRIPLET COVERAGE 80° + 80°				
Microphone Orientation	Distance between microphones	X coordinates	Y1 coordinates (for both left and right microphones)	Microphone Position Time Offset (MPTO)
90° (R)	<i>29.5 cms</i>	+ 24 cms	17.5 cms	<i>-9°</i>
270° (L)		- 24 cms		
80° (R)	<i>32 cms</i>	+ 24.5 cms	20.5 cms	<i>No Offset</i>
280° (L)		- 24.5 cms		
70° (R)	<i>34.5 cms</i>	+ 25 cms	23.5 cms	<i>+8°</i>
290° (L)		- 25 cms		
60° (R)	<i>35 cms</i>	+ 26.5 cms	26.5 cms	<i>+15°</i>
300° (L)		- 26.5 cms		
50° (R)	<i>40 cms</i>	+ 27.5 cms	29.5 cms	<i>+22°</i>
310° (L)		- 27.5 cms		
40° (R)	<i>43cms</i>	+ 29.5 cms	31.5 cms	<i>+27°</i>
320° (L)		- 29.5 cms		

From the above table (Front Triplet Coverage of 80° + 80°) note « the microphone orientation », « X » coordinates and « Y1 » coordinates for the desired configuration of the Front Triplet. Then choose the combination « distance / angle » from the table below and note the **distance** between the left and right Back Pair microphones, and their **orientation**, and the « Y2 » coordinate

of the the Back Pair (with respect to the front facing centre microphone) and corresponding ETO (Electronic Time Offset). Please note that a negative ETO means that the Back Pair will be delayed with respect to the Front Triplet by the requisite amount. This is all the information that you need to set up the array.

TABLE 5b						
LATERAL PAIRS		BACK PAIR				
<i>Lateral Segment Coverage</i>	Electronic Time Offset ETO	<i>Back Segment Coverage</i>	Mic Orient.	Angle between mics	Distance between mics	Y2 Coord
<i>55°</i>	- 0.75 mS	<i>90°</i>	140°(R) 220°(L)	<i>80°</i>	27 cms	85.3 cms
<i>60°</i>	- 0.7 mS	<i>80°</i>	140°(R) 220°(L)	<i>80°</i>	32 cms	80 cms
<i>65°</i>	- 0.7 mS	<i>70°</i>	135°(R) 225°(L)	<i>90°</i>	36 cms	76.5 cms
<i>70°</i>	- 0.6 mS	<i>60°</i>	135°(R) 225°(L)	<i>90°</i>	45 cms	71 cms
<i>75°</i>	- 0.7 mS	<i>50°</i>	130°(R) 230°(L)	<i>100°</i>	55 cms	71 cms
<i>80°</i>	- 0.76 mS	<i>40°</i>	120°(R) 240°(L)	<i>120°</i>	68 cms	76 cms

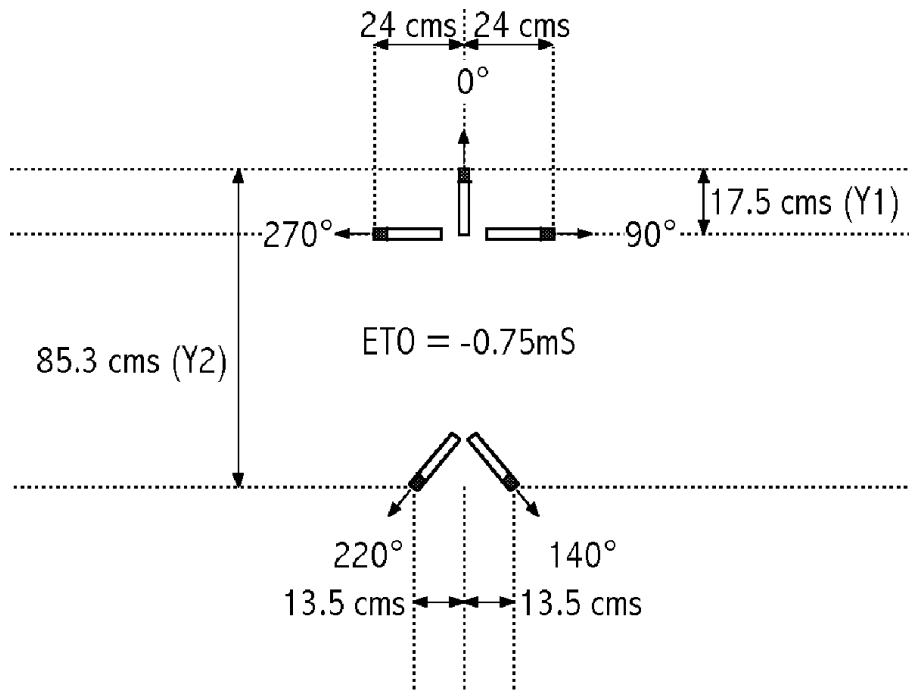

Figure 9 : Table 5a / line 1 : Table 5b / line 1

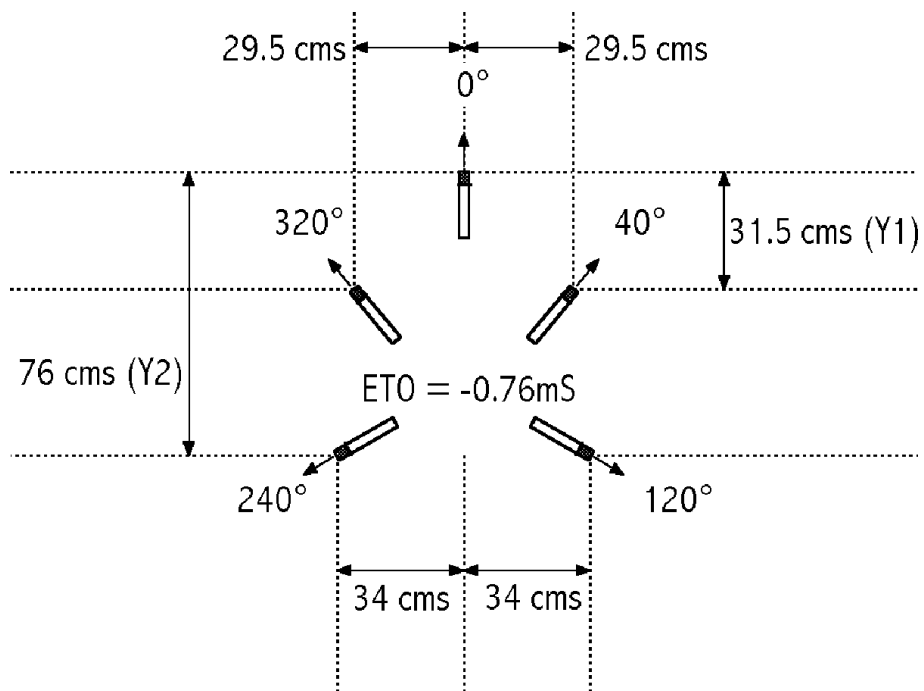

Figure 10 : Table 5a / line 6 : Table 5b / line 6

TABLE 6a				
FRONT TRIPLET COVERAGE 72° + 72°				
Microphone Orientation	Distance between microphones	X coordinates	Y1 coordinates (for both left and right microphones)	Microphone Position Time Offset (MPTO)
90° (R)	<i>35 cms</i>	+ 30.5 cms	17 cms	-15.6°
270° (L)		- 30.5 cms		
80° (R)	<i>37 cms</i>	+ 31 cms	20.5 cms	-6°
280° (L)		- 31 cms		
72° (R)	<i>39 cms</i>	+ 31.5 cms	23 cms	<i>No Offset</i>
288° (L)		- 31.5 cms		
60° (R)	<i>42.5 cms</i>	+ 33 cms	26.5 cms	+9°
300° (L)		- 33 cms		
50° (R)	<i>45 cms</i>	+ 34 cms	29.5 cms	+15.5°
310° (L)		- 34 cms		
40° (R)	<i>48.5 cms</i>	+ 36.5 cms	31.5 cms	+20.9°
320° (L)		- 36.5 cms		

From the above table (Front Triplet Coverage of 72° + 72°) note « the microphone orientation », « X » coordinates and « Y1 » coordinates for the desired configuration of the Front Triplet. Then choose the combination « distance / angle » from the table below and note the **distance** between the left and right Back Pair microphones, and their **orientation**, and the « Y2 » coordinate of the the Back Pair (with respect to the front facing centre

microphone) and corresponding ETO (Electronic Time Offset). Please note that a negative ETO means that the Back Pair will be delayed with respect to the Front Triplet by the requisite amount. And inversely, a positive ETO means that the Front Triplet is delayed with respect to the Back Pair. This is all the information that you need to set up the array.

TABLE 6b						
LATERAL PAIRS		BACK PAIR				
<i>Lateral Segment Coverage</i>	Electronic Time Offset ETO	<i>Back Segment Coverage</i>	Mic Orient.	Angle between mics	Distance between mics	Y2 Coord
63°	+ 0.2 mS	90°	140°(R) 220°(L)	80°	27 cms	67.5 cms
68°	+ 0.07 mS	80°	140°(R) 220°(L)	80°	32 cms	63.5 cms
72°	No Offset	72°	135°(R) 225°(L)	90°	39 cms	60 cms
78°	- 0.19 mS	60°	135°(R) 225°(L)	90°	45 cms	60.1 cms
83°	- 0.36 mS	50°	130°(R) 230°(L)	100°	55 cms	61.1 cms
88°	- 0.43 mS	40°	120°(R) 240°(L)	120°	68 cms	62 cms

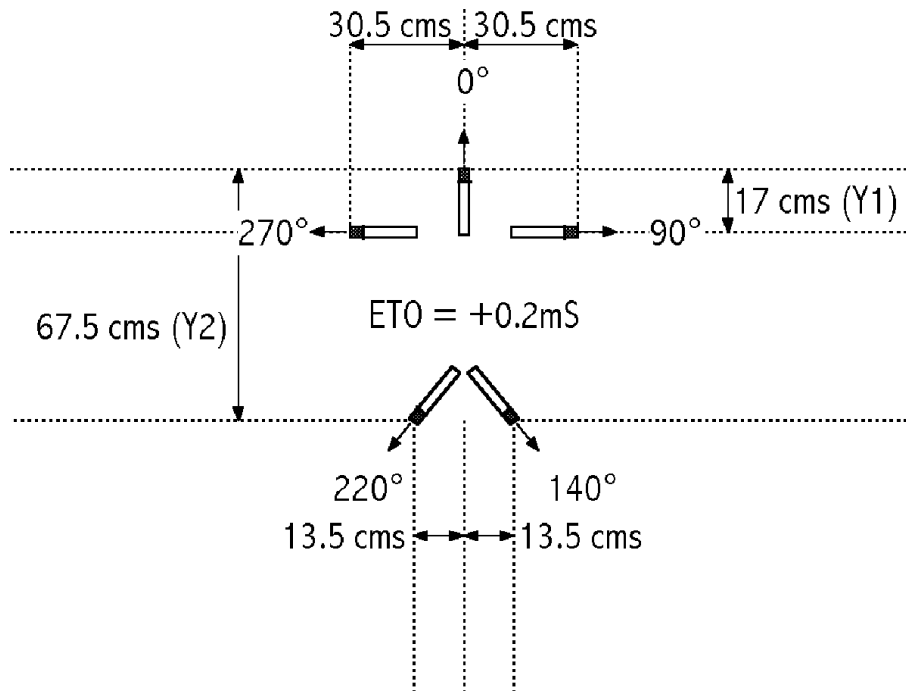

Figure 11 : Table 6a / line 1 : Table 6b / line 1

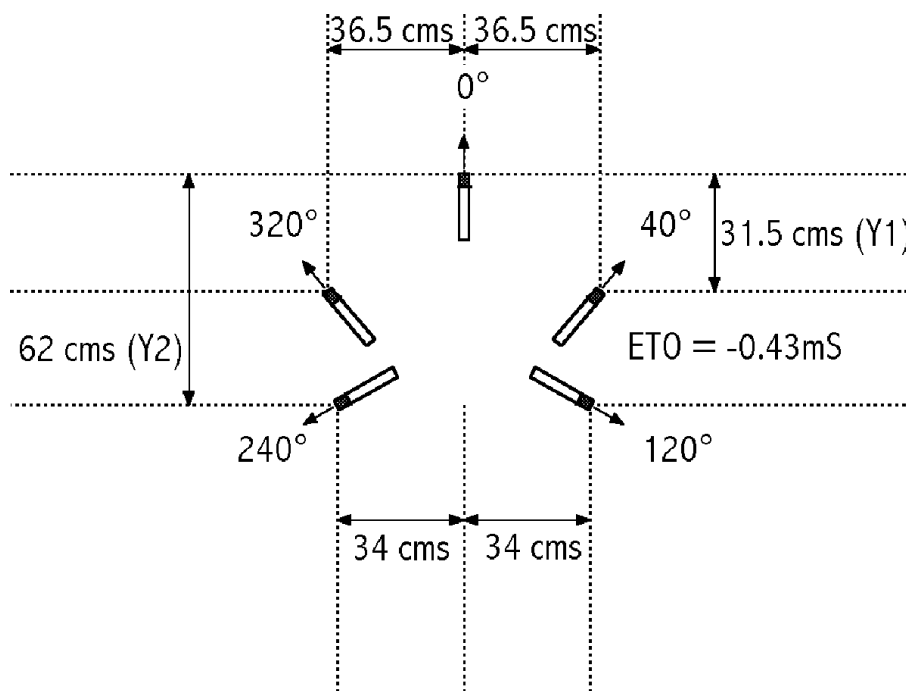

Figure 12 : Table 6a / line 6 : Table 6b / line 6

TABLE 7a				
FRONT TRIPLET COVERAGE 60° + 60°				
Microphone Orientation	Distance between microphones	X coordinates	Y1 coordinates (for both left and right microphones)	Microphone Position Time Offset (MPTO)
90° (R)	<i>46 cms</i>	+ 42.5 cms	17 cms	-23°
270° (L)		- 42.5 cms		
80° (R)	<i>48 cms</i>	+ 43.5 cms	20.5 cms	-15°
280° (L)		- 43.5 cms		
70° (R)	<i>50.2 cms</i>	+ 44.5 cms	23.5 cms	- 7°
288° (L)		- 44.5 cms		
60° (R)	<i>53 cms</i>	+ 46 cms	26.5 cms	<i>No Offset</i>
300° (L)		- 46 cms		
50° (R)	<i>56 cms</i>	+ 47.5 cms	29.5 cms	+7°
310° (L)		- 47.5 cms		
40° (R)	<i>59 cms</i>	+ 50 cms	31.5 cms	+12°
320° (L)		- 50 cms		

From the above table (Front Triplet Coverage of 60° + 60°) note « the microphone orientation », « X » coordinates and « Y1 » coordinates for the desired configuration of the Front Triplet. Then choose the combination « distance / angle » from the table below and note the **distance** between the left and right Back Pair microphones, and their **orientation**, and the « Y2 » coordinate of the the Back Pair (with respect to the front facing centre

microphone) and corresponding ETO (Electronic Time Offset). Please note that a negative ETO means that the Back Pair will be delayed with respect to the Front Triplet by the requisite amount. And inversely, a positive ETO means that the Front Triplet is delayed with respect to the Back Pair. This is all the information that you need to set up the array.

TABLE 7b						
LATERAL PAIRS		BACK PAIR				
<i>Lateral Segment Coverage</i>	Electronic Time Offset ETO	<i>Back Segment Coverage</i>	Mic Orient.	Angle between mics	Distance between mics	Y2 Coord
<i>75°</i>	+ 0.69 mS	<i>90°</i>	140°(R) 220°(L)	80°	27 cms	57 cms
<i>80°</i>	+ 0.56 mS	<i>80°</i>	140°(R) 220°(L)	80°	32 cms	53 cms
<i>85°</i>	+ 0.42 mS	<i>70°</i>	135°(R) 225°(L)	90°	36 cms	51 cms
<i>90°</i>	+ 0.28 mS	<i>60°</i>	135°(R) 225°(L)	90°	45 cms	49 cms
<i>95°</i>	+ 0.1 mS	<i>50°</i>	130°(R) 230°(L)	100°	55 cms	49 cms
<i>100°</i>	- 0.1 mS	<i>40°</i>	120°(R) 240°(L)	120°	68 cms	52 cms

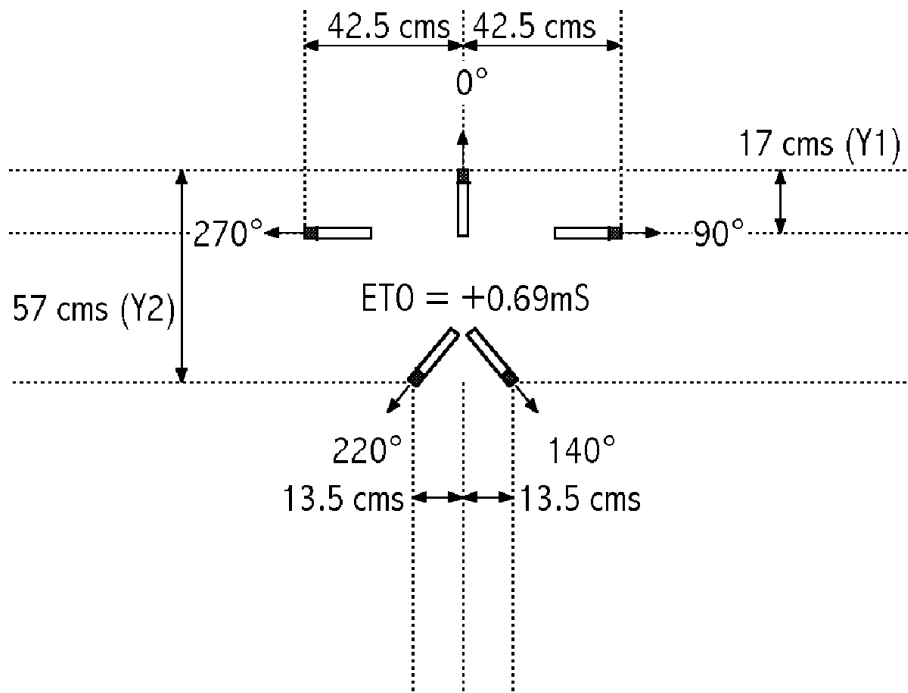

Figure 13 : Table 7a / line 1 : Table 7b / line 1

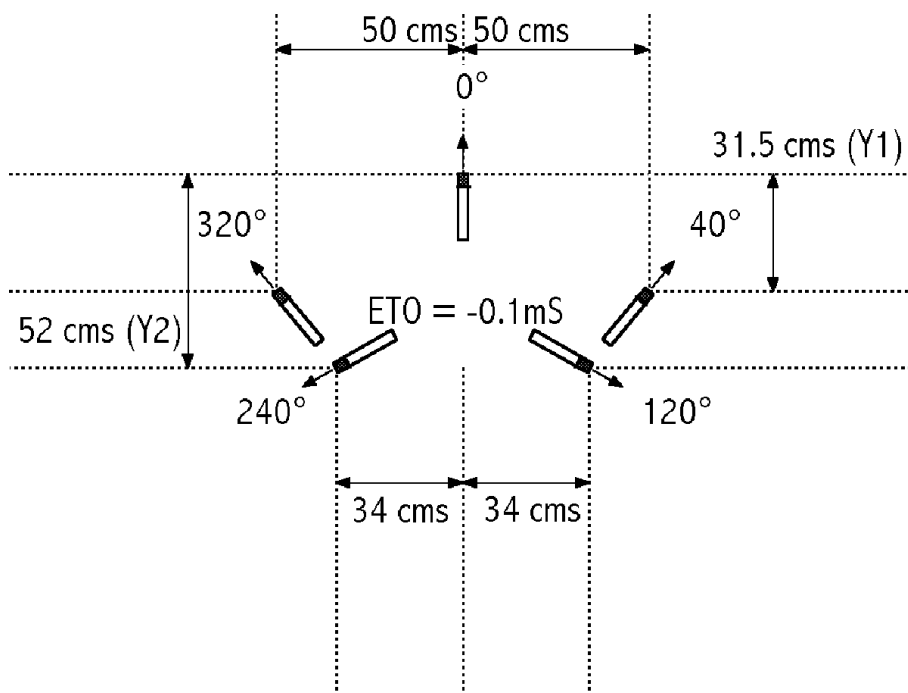

Figure 14 : Table 7a / line 6 : Table 7b / line 6

TABLE 8a				
FRONT TRIPLET COVERAGE 50° + 50°				
Microphone Orientation	<i>Distance between microphones</i>	X coordinates	Y1 coordinates (for both left and right microphones)	<i>Microphone Position Time Offset (MPTO)</i>
90° (R)	<i>61 cms</i>	+ 58.5 cms	17 cms	-28.5°
270° (L)		- 58.5 cms		
80° (R)	<i>62 cms</i>	+ 58 cms	21 cms	-20°
280° (L)		- 58 cms		
70° (R)	<i>63.9 cms</i>	+ 59 cms	24 cms	- 13
288° (L)		- 59 cms		
60° (R)	<i>66.5 cms</i>	+ 61 cms	27 cms	-6°
300° (L)		- 61 cms		
50° (R)	<i>69.5 cms</i>	+ 63 cms	29.5 cms	<i>No Offset</i>
310° (L)		- 63 cms		
40° (R)	<i>72.5 cms</i>	+ 65 cms	32 cms	+6°
320° (L)		- 65 cms		

From the above table (Front Triplet Coverage of 50° + 50°) note « the microphone orientation », « X » coordinates and « Y1 » coordinates for the desired configuration of the Front Triplet. Then choose the combination « distance / angle » from the table below and note the **distance** between the left and right Back Pair microphones, and their **orientation**, and the « Y2 » coordinate

of the the Back Pair (with respect to the front facing centre microphone) and corresponding ETO (Electronic Time Offset). Please note that a positive ETO means that the Front Triplet is delayed with respect to the Back Pair by the requisite amount.. This is all the information that you need to set up the array.

TABLE 8b						
LATERAL PAIRS		BACK PAIR				
<i>Lateral Segment Coverage</i>	Electronic Time Offset ETO	<i>Back Segment Coverage</i>	Mic Orient.		Distance between mics	Y2 Coord
<i>90°</i>	No Solution	<i>80°</i>	140°(R) 220°(L)	<i>80°</i>	32 cms	-
<i>95°</i>	No Solution	<i>70°</i>	135°(R) 225°(L)	<i>90°</i>	36 cms	-
<i>100°</i>	No Solution	<i>60°</i>	135°(R) 225°(L)	<i>90°</i>	45 cms	-
<i>105°</i>	+ 0.5 mS	<i>50°</i>	130°(R) 230°(L)	<i>100°</i>	55 cms	42.5 cms
<i>110°</i>	+ 0.28 mS	<i>40°</i>	120°(R) 240°(L)	<i>120°</i>	68 cms	45.5 cms
<i>114°</i>	No Offset	<i>32°</i>	140°(R) 220°(L)	<i>120°</i>	103 cms	52.5 cms

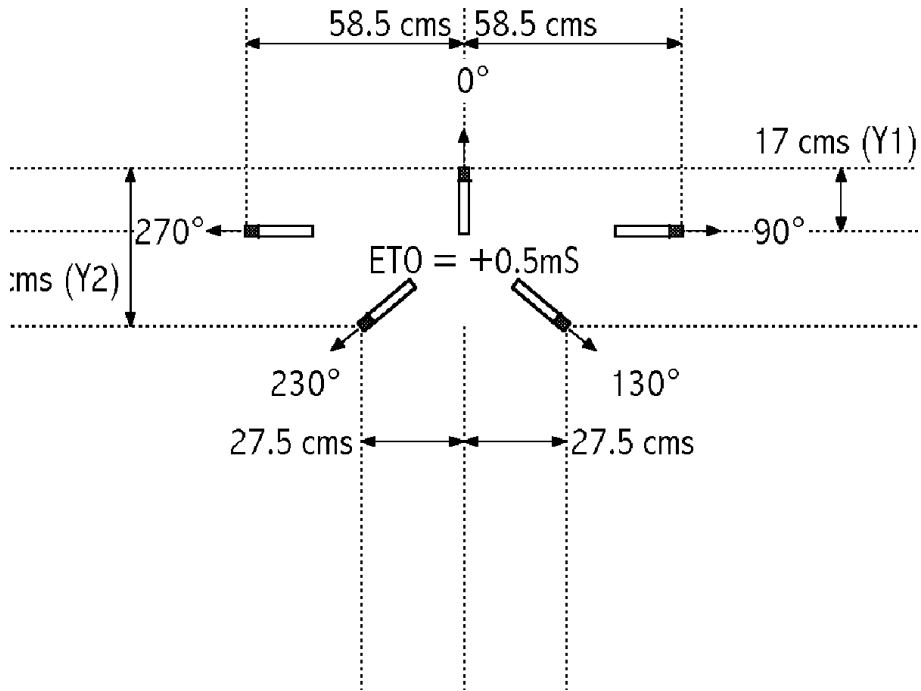

Figure 15 : Table 8a / line 1 : Table 8b / line 4

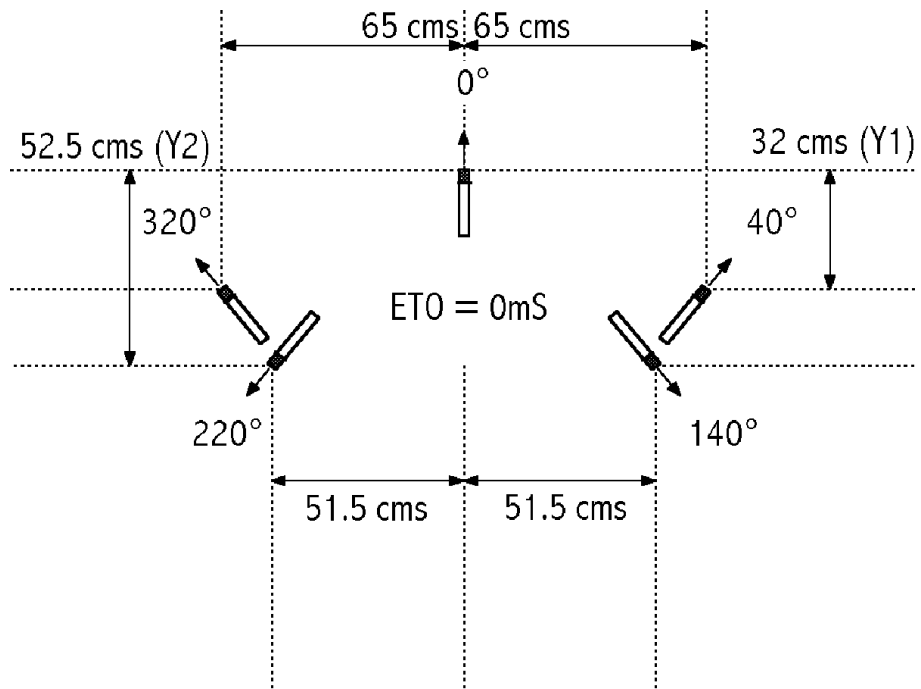

Figure 16 : Table 8a / line 6 : Table 8b / line 6

REFERENCES :

1. 1999 : 107th AES Convention in New York : Preprint 4997
« Microphone Array Analysis for Multichannel Sound Recording » by Michael Williams and Guillaume Le Dû
2. 2000 : 108th AES Convention in Paris : Preprint 5157
« Multichannel Microphone Array Design »
by Michael Williams and Guillaume Le Dû
3. « The Stereophonic Zoom » by Michael Williams
4. 1991 : 91st AES Convention in New York – preprint 3157
« Microphone Arrays for Natural Multiphony »
by Michael Williams.
5. 2000 : VDT in Hannover
« Loudspeaker Configuration and Channel Crosstalk
in Multichannel Microphone Array Design »
by Michael Williams and Guillaume Le Dû
6. 1987 : 82nd AES Convention in London : Preprint 2466
« Unified Theory of Microphones Systems for Stereophonic
Sound Recording » by Michael Williams

EMAIL CORRSPONDANCE :

Michael WILLIAMS : Soundsscot@aol.com
Guillaume LE DÛ : ledudld@worldnet.fr

ANNEXE

The authors of this paper have received many requests to publish the original SRA diagrams (3)(6) but covering a much wider range of distance between the microphones. Although it is possible to see an approximate correlation between the SRA values shown in this diagram and the values presented in the MMAD tables, the Intensity/Time Difference curves are by no means linear. Therefore the introduction of any amount of offset will cause a certain amount of asymmetry in these curves and intersection with the psychoacoustic limits of the listening configuration will obviously give somewhat different values for the relative coverage angles.

The expanded SRA diagram is shown in Figure 17. Please note that the SRA angle is show as +/- a value, indicating the value clockwise and anticlockwise. The total coverage is therefore twice the shown numerical value.

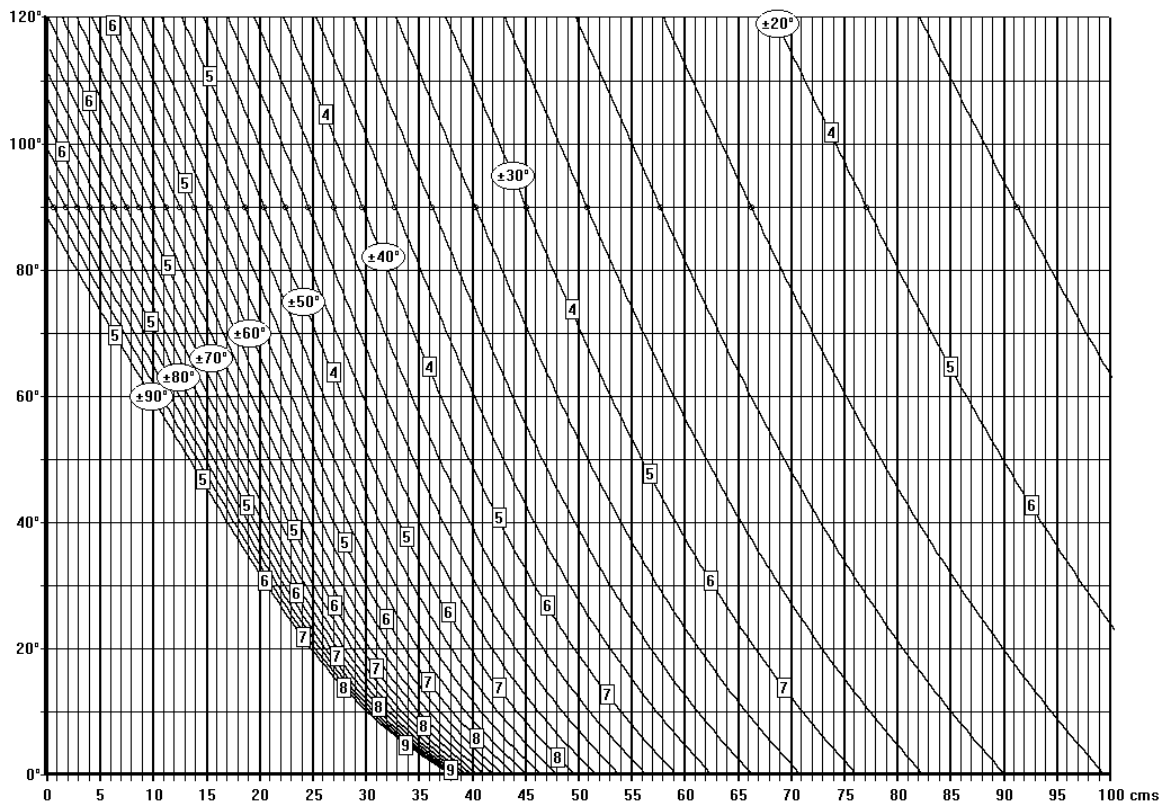

Figure17 : Stereophonic Recording Angle Diagram for Cardioid Microphones